

10G SFP+ CWDM Optical Transceiver

PN: OP3940D-xx

Product Specification

Features:

- ✧ Supports 1.0 to 11.3Gb/s bit rates
- ✧ Hot-Pluggable SFP+ form factor
- ✧ Duplex LC connector
- ✧ 1471~1611nm CWDM EML transmitter, PIN photo-detector
- ✧ 16dB optical link budget
- ✧ Built-in digital diagnostic functions
- ✧ Single +3.3V Power Supply
- ✧ Operating case temperature: 0~ 70°C
- ✧ Power dissipation: <1.5W
- ✧ RoHS compliant

Applications:

- ✧ 10G Ethernet
- ✧ SDH/SONET
- ✧ Fibre Channel

Description:

Opway' OP3940D-xx is a very compact 10Gb/s optical transceiver module for serial optical communication applications at 10Gb/s. The OP3940D-xx converts a 10Gb/s serial electrical data stream to 10Gb/s optical output signal and a 10Gb/s optical input signal to 10Gb/s serial electrical data streams. The high speed 10Gb/s electrical interface is fully compliant with SFI specification.

The high performance CWDM EML transmitter and high sensitivity PIN receiver provide superior performance for Multiple applications.

The SFP+ Module compliant with SFF-8431, SFF-8432. Digital diagnostics functions are available via a 2-wire serial interface, as specified in SFF-8472.

The fully SFP compliant form factor provides hot pluggability, easy optical port upgrades and low EMI emission.

● **Absolute Maximum Ratings**

Parameter	Symbol	Min.	Typical	Max.	Unit
Power Supply Voltage	VCC	0		3.6	V
Storage Temperature	Ts	-40		85	°C
Operating Case Temperature	TA	0		70	°C
Relative Humidity	RH	0		85	%

● **Electrical Characteristics**

Parameter	Symbol	Min.	Typical	Max.	Unit	Note
Supply Voltage	Vcc	3.135		3.465	V	
Supply Current	Icc			455	mA	
Power Consumption	P			1.5	W	
Transmitter Section:						
Input differential impedance	R _{in}		100		Ω	1
Differential input voltage swing	V _{in,pp}	100		1000	mV	
Transmit Disable Voltage	V _D	2		V _{cc}	V	
Transmit Enable Voltage	V _{EN}	V _{ee}		V _{ee} +0.8	V	
Receiver Section:						
Differential output voltage swing	V _O	120		800	mV	
LOS Fault	V _{losfault}	2		V _{CC_host}	V	2
LOS Normal	V _{los norm}	V _{ee}		V _{ee} +0.8	V	2

Notes:

1. Connected directly to TX data input pins. AC coupling from pins into laser driver IC.
2. LOS is an open collector output. Should be pulled up with 4.7k – 10kΩ on the host board. Normal operation is logic 0; loss of signal is logic 1.

● **Optical Parameters**

Parameter	Symbol	Min.	Typical	Max.	Unit	Note
Transmitter Section:						
Center Wavelength	λ _t	λ-6.5	λ	λ+6.5	nm	
Spectral width	Δλ			0.4	nm	
Side Mode Suppression Ratio	SMSR	30			dB	
Average Optical Power	P _{avg}	0		+5.5	dBm	
Laser Off Power	P _{off}			-30	dBm	
Extinction Ratio	ER	6			dB	
Receiver Section:						
Center Wavelength	λ _r	1260		1620	nm	
Receiver Sensitivity	Sen			-16	dBm	1
Input Saturation Power(Overload)	Sat	0			dBm	
Los Assert	LOS _A	-30		-	dBm	

Los Dessert	LOS _D			-17	dBm	
Los Hysteresis	LOS _H	0.5			dB	

Notes:

1. Measured with a PRBS 2³¹-1 test pattern, @10.3125Gb/s, BER < 10⁻¹².

● **Pin Assignment**

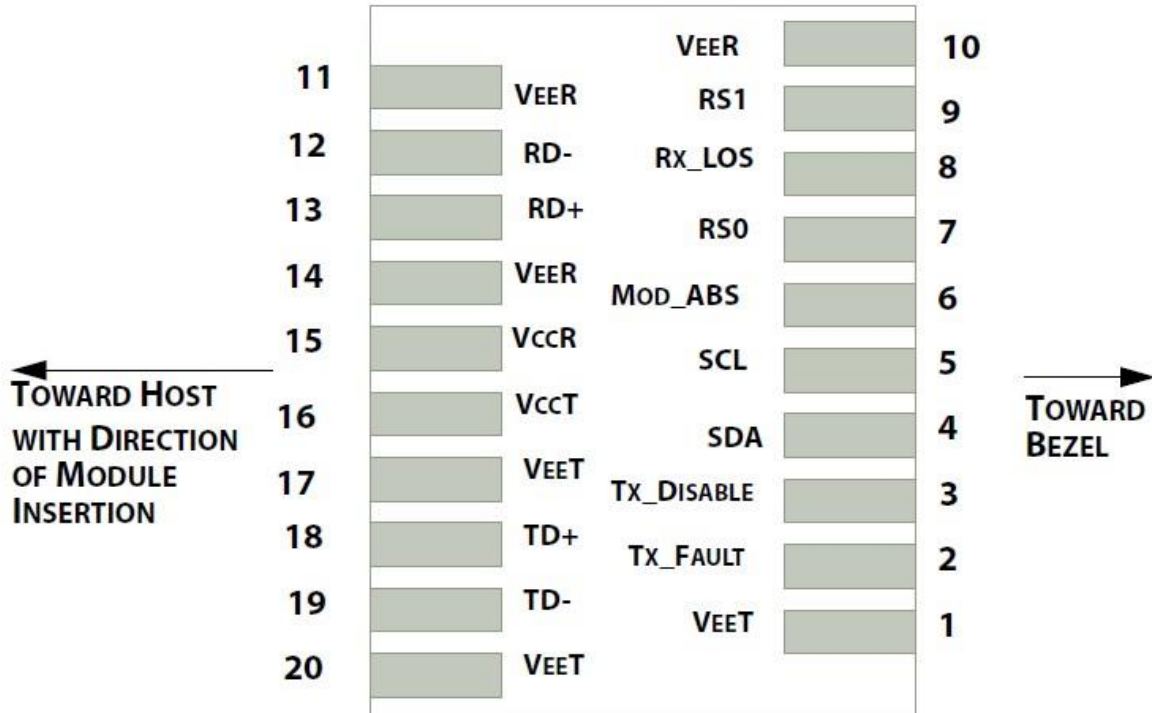

Diagram of Host Board Connector Block Pin Numbers and Names

● **Pin Function Definitions**

PIN #	Name	Function	Notes
1	VeeT	Module transmitter ground	1
2	Tx Fault	Module transmitter fault	2
3	Tx Disable	Transmitter Disable; Turns off transmitter laser output	3
4	SDA	2 wire serial interface data input/output (SDA)	
5	SCL	2 wire serial interface clock input (SCL)	
6	MOD-ABS	Module Absent, connect to VeeR or VeeT in the module	2
7	RS0	Rate Select 0. Not Used	
8	LOS	Receiver Loss of Signal Indication	4
9	RS1	Rate Select 1. Not Used	
10	VeeR	Module receiver ground	1
11	VeeR	Module receiver ground	1
12	RD-	Receiver inverted data out put	
13	RD+	Receiver non-inverted data out put	
14	VeeR	Module receiver ground	1
15	VccR	Module receiver 3.3V supply	

16	VccT	Module transmitter 3.3V supply	
17	VeeT	Module transmitter ground	1
18	TD+	Transmitter non-inverted data out put	
19	TD-	Transmitter inverted data out put	
20	VeeT	Module transmitter ground	1

Notes:

- 1.The module ground pins shall be isolated from the module case.
- 2.This pin is an open collector/drain output pin and shall be pulled up with 4.7K-10Kohms to Host_Vcc on the host board.
- 3.This pin shall be pulled up with 4.7K-10Kohms to VccT in the module.
- 4.This pin is an open collector/drain output pin and shall be pulled up with 4.7K-10Kohms to Host_Vcc on the host board.

● SFP Module EEPROM Information and Management

The SFP modules implement the 2-wire serial communication protocol as defined in the SFF -8472. The serial ID information of the SFP modules and Digital Diagnostic Monitor parameters can be accessed through the I2C interface at address A0h and A2h.

The memory is mapped in Table 1.

For more details of the memory map and byte definitions, please refer to the SFF-8472, “Digital Diagnostic Monitoring Interface for Optical Transceivers”. The DDM parameters have been internally calibrated.

Table 1. Digital Diagnostic Memory Map (Specific Data Field Descriptions)

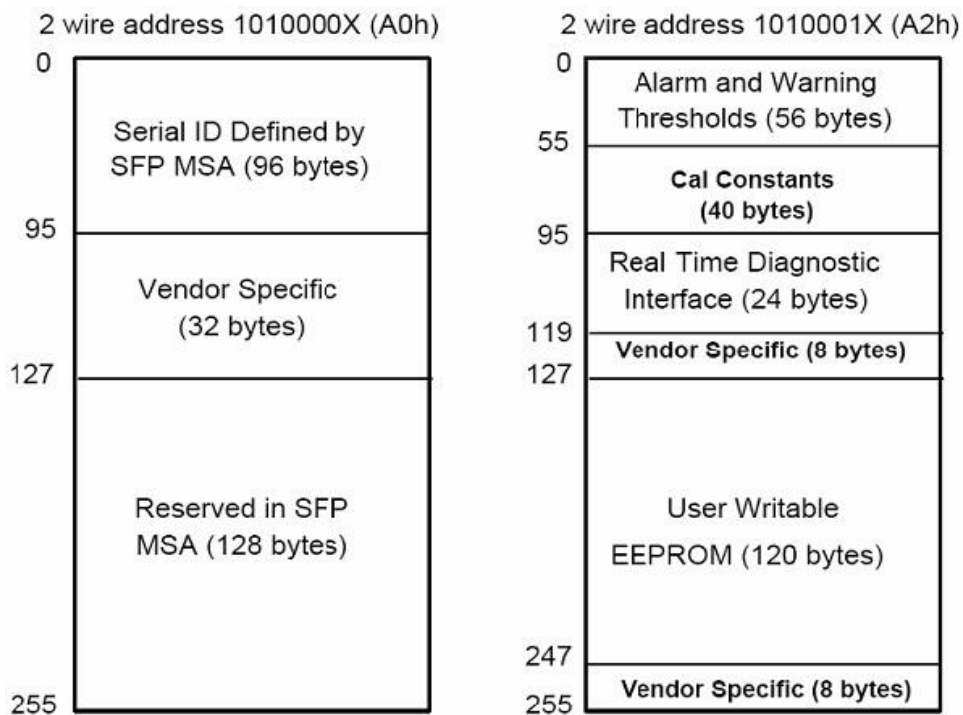

● **Digital Diagnostic Monitor Characteristics**

Data Address	Parameter	Accuracy	Unit
96-97	Transceiver Internal Temperature	±3.0	°C
98-99	VCC Internal Supply Voltage	±3.0	%
100-101	Laser Bias Current	±10	%
102-103	Tx Output Power	±3.0	dB
104-105	Rx Input Power	±3.0	dB

● **Recommended Circuit**

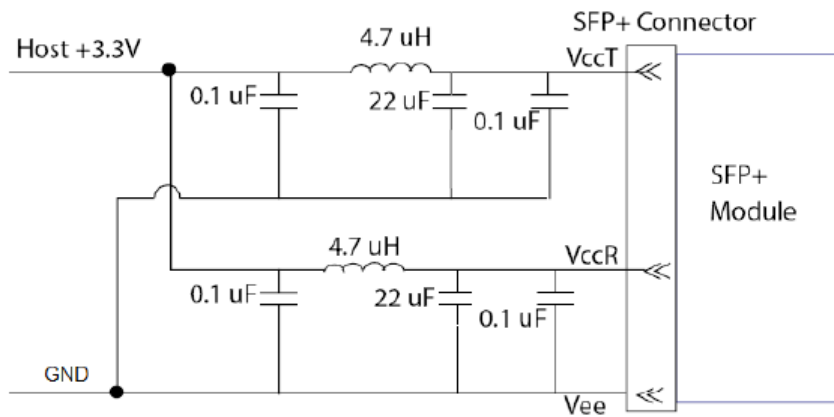

Recommended Host Board Power Supply Circuit

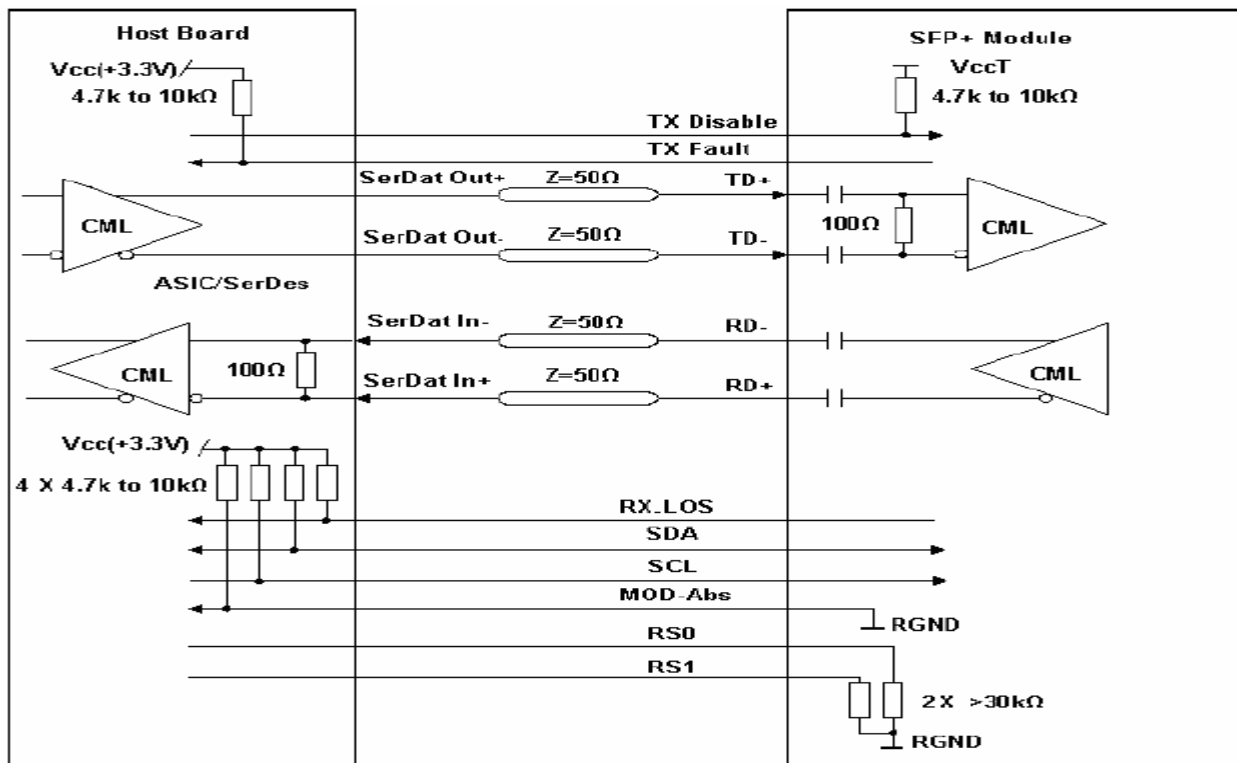

Recommended High-speed Interface Circuit

● **Mechanical Dimensions(Unit:mm)**

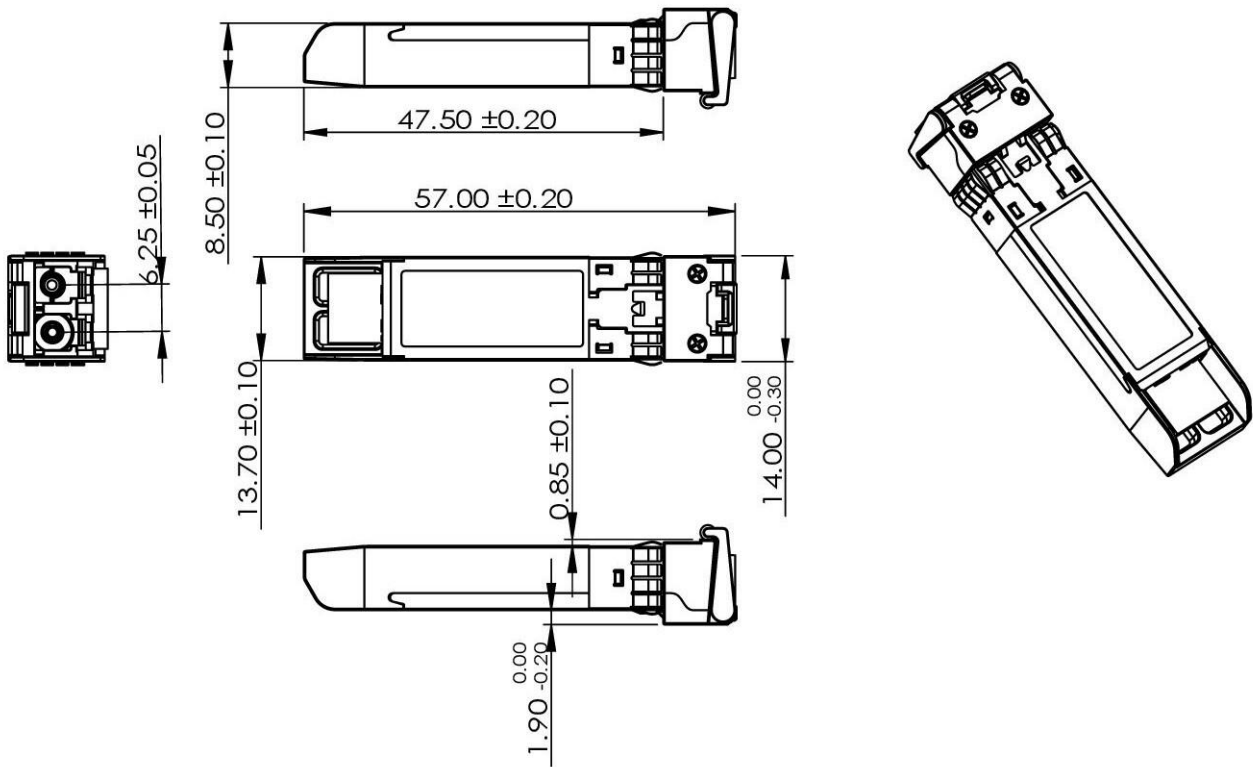

● **Order Information**

Part No.	Data Rate	Central wavelength	Optical Link budget	Recommend Distance
OP3940D-47	10Gbps	1471nm	16dB	40km
OP3940D-49	10Gbps	1491nm	16dB	40km
OP3940D-51	10Gbps	1511nm	16dB	40km
OP3940D-53	10Gbps	1531nm	16dB	40km
OP3940D-55	10Gbps	1551nm	16dB	40km
OP3940D-57	10Gbps	1571nm	16dB	40km
OP3940D-59	10Gbps	1591nm	16dB	40km
OP3940D-61	10Gbps	1611nm	16dB	40km

● **Document Revision**

Version No.	Date	Reviser	Description
V1.0	2023-11-13	Kevin	Template update

OPWAY reserves the right to make changes to the products or information contained herein without notice. No liability is assumed as a result of their use or application. No rights under any patent accompany the sale of any such products or information.

Published by OPWAY Communication Inc.

Copyright © OPWAY

All Rights Reserved